

COBRA TERROR DROME INSTRUCTIONS

Remove all pieces from plastic frames. If you have difficulty, use safety scissors.

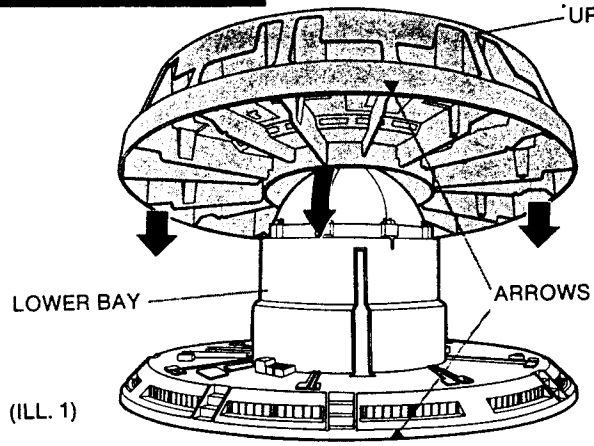

1 When removing Terror Drome launch base from package, make sure arrows on upper deck and lower bay line up properly. (ILL. 1)

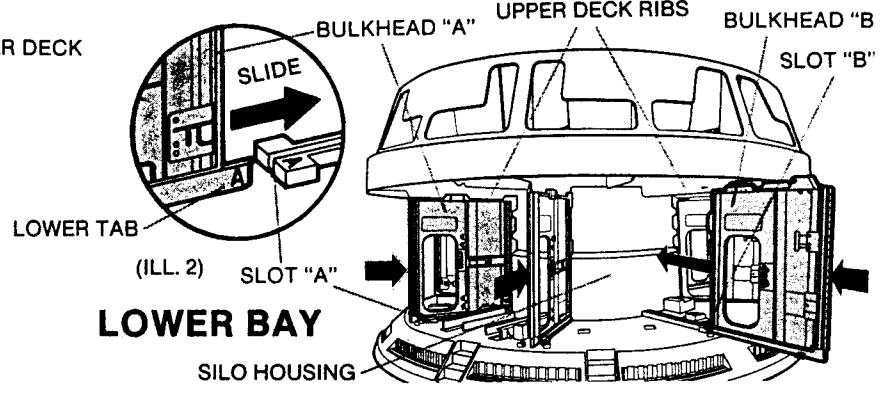

LOWER BAY

2 Note: Locate bulkheads with "A" and "B" marked on lower tabs. Slide 5 bulkheads (marked "A") into slots in lower bay (marked "A"). Alternate sliding tabs on top of bulkheads onto ribs underneath upper deck. Snap tabs on rear of bulkheads into silo housing. Repeat with 3 bulkheads (marked "B") and slots in lower bay (marked "B"). (ILL. 2)

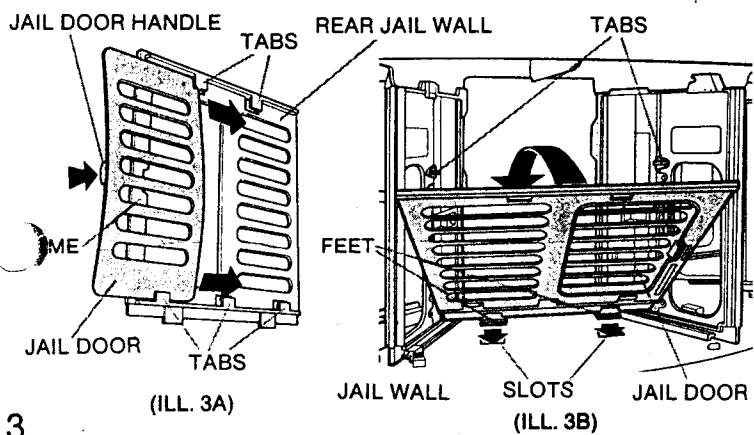

3

A Locate orange jail door panel and grey jail panel. With jail door handle facing jail wall, slide door under tabs in wall. Bend door slightly so handle pops over wall frame. (ILL. 3A)

B With jail door on INSIDE of wall, HOOK feet on bottom of jail wall into slots in lower bay. Push sides of jail wall past tabs on bulkheads to secure. (ILL. 3B)

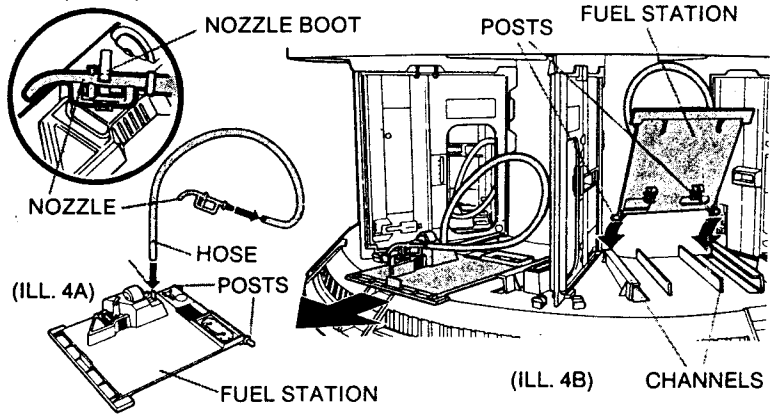

4

A Fit one end of fuel hose over post on fuel station. Insert fuel nozzle into other end of fuel hose. Snap fuel nozzle into nozzle boot. (ILL. 4A) (1 extra nozzle included)

B From back of channels in lower bay, insert 2 posts on fuel station underneath channels and slide station toward you. Repeat with second and third fuel stations. (Fuel stations extend out.) (ILL. 4B)

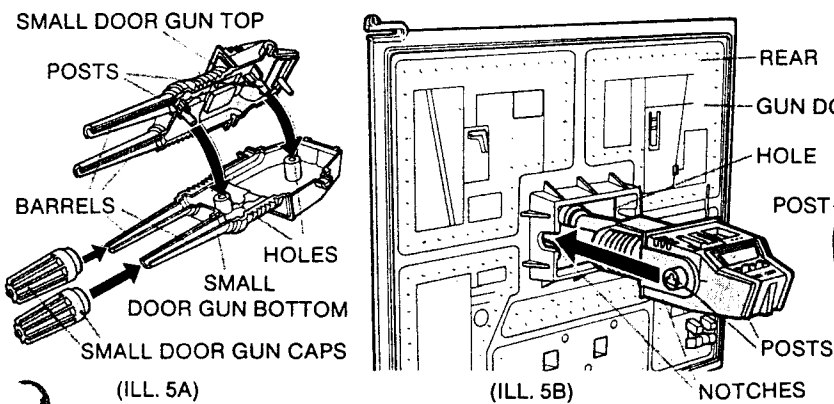

5

A Insert posts on smaller door gun top into holes in smaller door gun bottom. Press firmly together. Press smaller door gun caps over gun barrels. (Tap caps onto hard surface to tighten fit if necessary.) (ILL. 5A)

B From rear of gun door, insert gun barrels through hole in door. Snap posts into notches. Repeat with second door gun and door. (ILL. 5B)

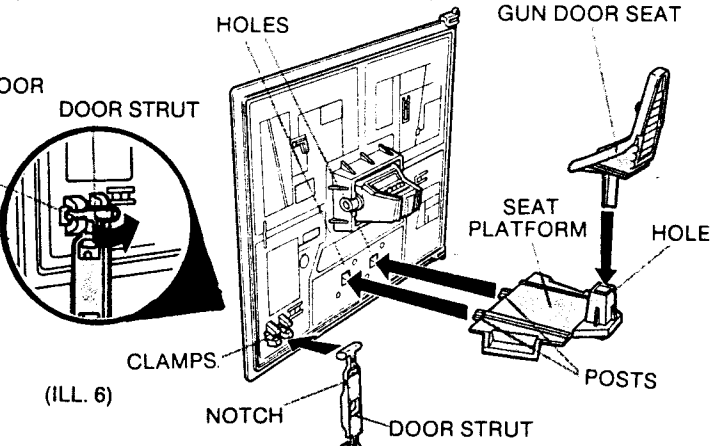

6 With notch on door strut facing door, insert one side of post into clamp on door and snap other side into place. Fit posts on seat platform into holes in door. Insert gun door seat into hole in seat platform. Repeat Step 6 with second gun door. (ILL. 6)

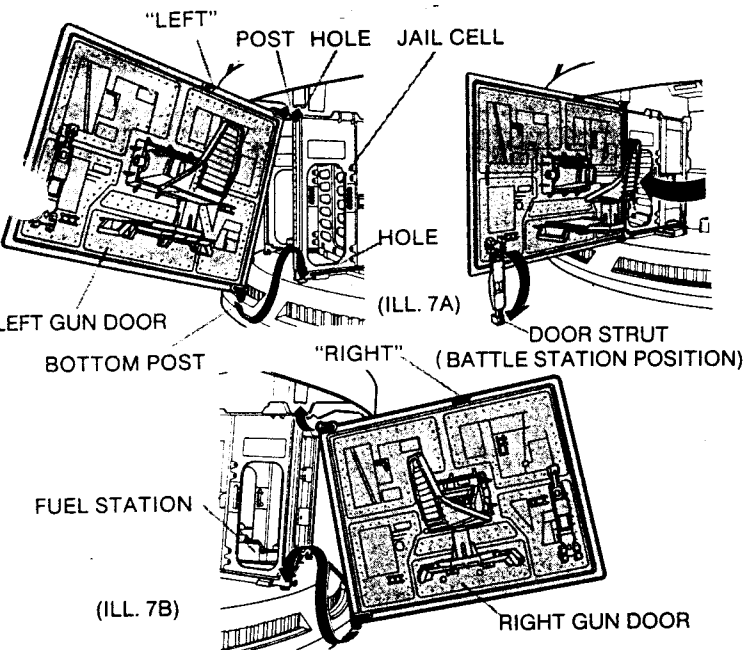

- 7 NOTE: Gun doors are marked "LEFT" and "RIGHT".
A (LEFT GUN DOOR FITS INTO LOWER BAY BETWEEN JAIL CELL AND LAUNCH LEVER.) Insert top post on left gun door into hole underneath upper deck. Slide bottom post into hole in lower bay floor. (Open door and lower door strut for battle station position.)
B Insert posts on RIGHT GUN DOOR into holes in lower bay located to the LEFT OF ONE OF THE FUEL STATIONS.



- 9 Fit launch lever over launch handle in lower bay. (Slide launch lever up and down to activate silo/elevator.) (ILL. 9)

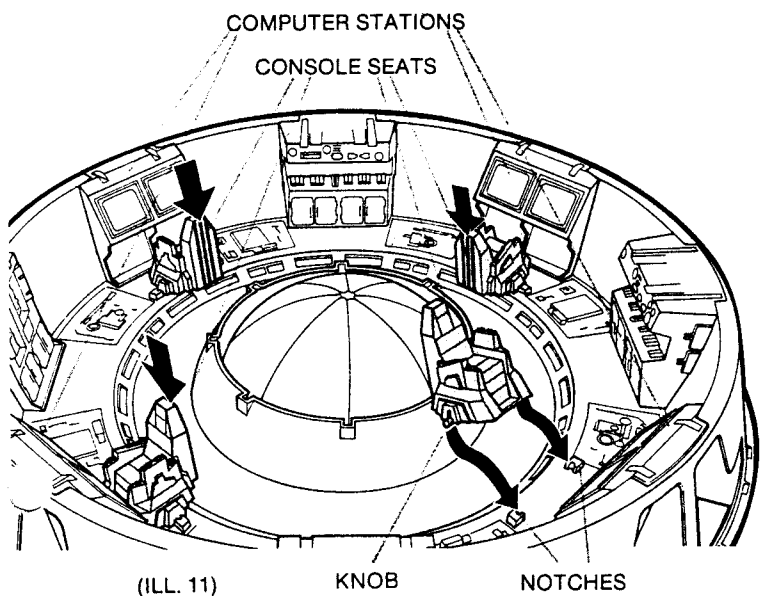

- 11 Snap knobs on console seats into notches facing computer stations. (Console seats recline.) (ILL. 11)

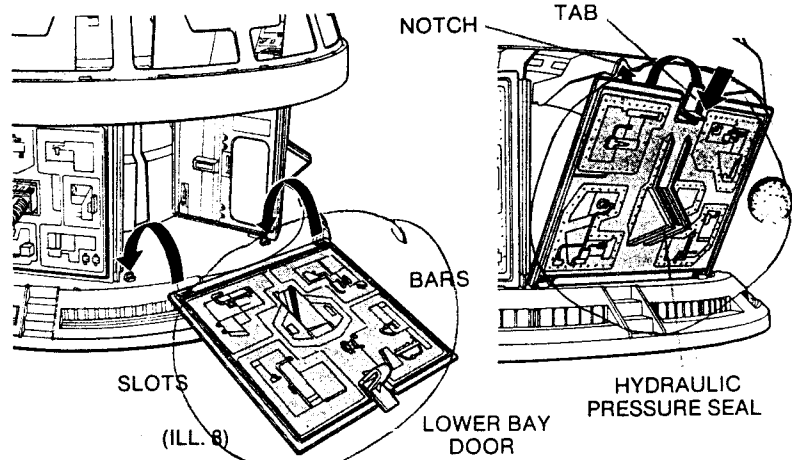

- 8 With hydraulic pressure seals facing out, snap bars on 6 lower bay doors into slots in lower bay. Snap top tab into notch underneath upper deck. (Push tab slightly to open doors.) NOTE: If doors do not close securely, make sure upper deck is pressed firmly onto lower bay. (ILL. 8)

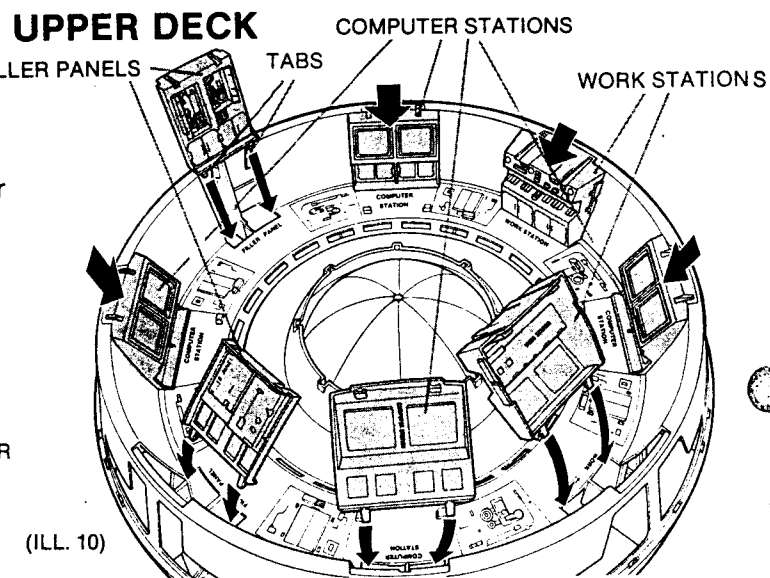

- 10 NOTE: Panels, stations and upper deck openings are marked accordingly on the backside of each. Slide bottom tabs on 2 filler panels into filler panel openings. Snap top tabs into place. Repeat with 2 work stations and 4 computer stations.

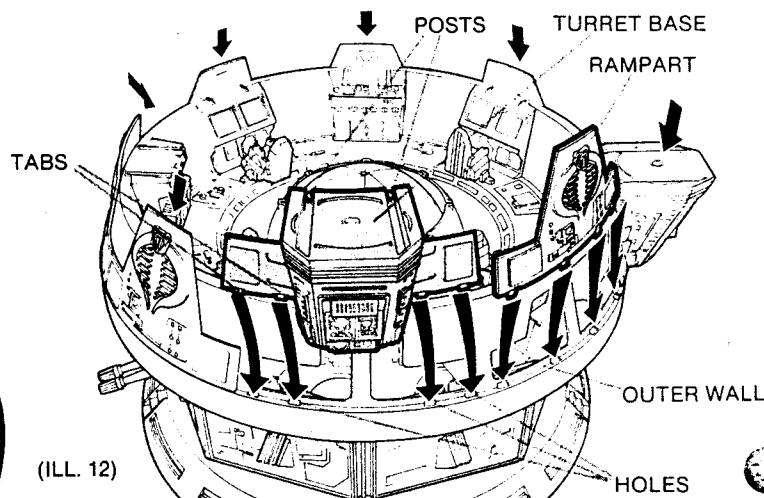

- 12 Insert tabs on turret base into holes in outer wall (opposite filler panel). Snap 2 top posts into wall. Attach second turret base onto outer wall opposite other filler panel. Attach 6 ramparts onto remaining outer walls. (ILL. 12)

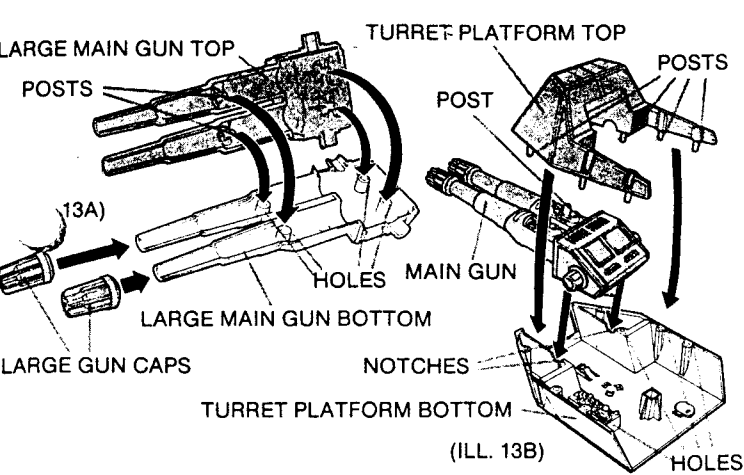

13 A Insert posts in large main gun top into holes in large main gun bottom. Press firmly together. Press large main gun caps over gun barrels. (Tap caps onto hard surface to tighten fit if necessary.) (ILL. 13A)

B Place 2 posts on main gun onto notches in turret platform bottom. Insert posts on turret platform top into holes in turret platform bottom. Press firmly together. (ILL. 13B)

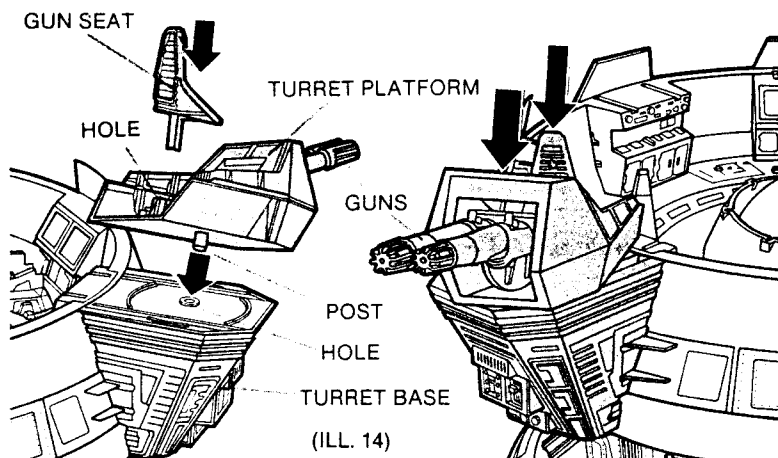

14 Fit cylinder on underside of turret platform into hole in turret base. With gun seat facing guns, insert seat into hole in turret platform. Repeat Step 13 and 14 with second turret platform. (ILL. 14)

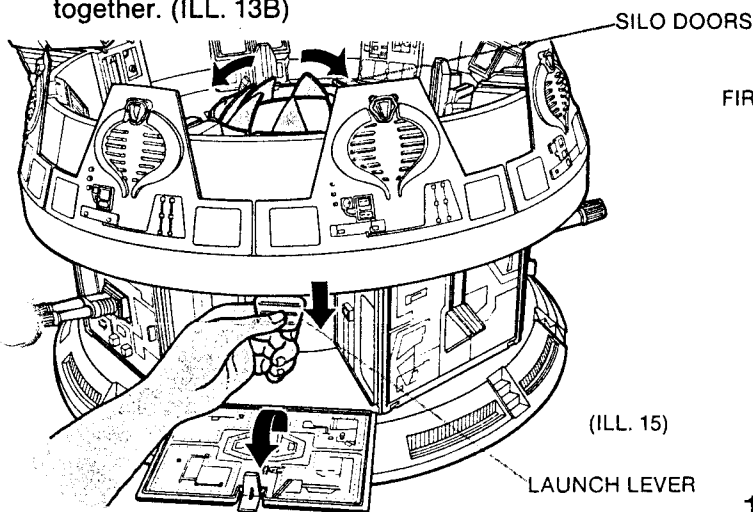

15 For Firebat landing: Press launch lever to open silo doors. (ILL. 15)

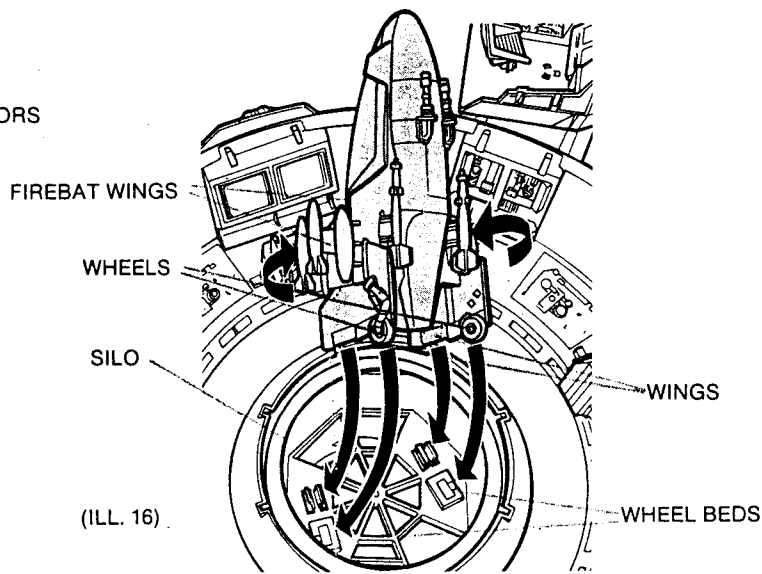

16 After assembling Firebat, fold Firebat wings and place into silo, tail first. Fit Firebat wheels into wheel beds first, then fit wings into slots. NOTE: To keep the Firebat undercover, lift the secret launch lever to lower Firebat and close silo doors!

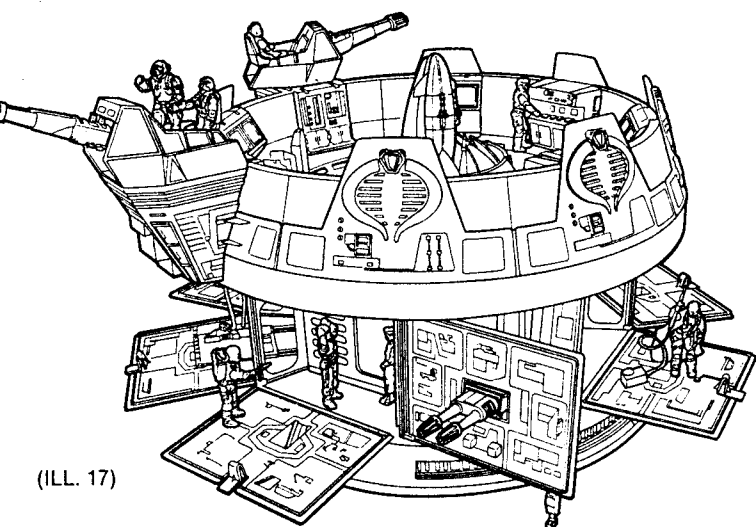

(ILL. 17)

Seat pilot A.V.A.C. at one of the command or battle stations or place him in the Firebat pilot's seat! Use your entire collection of G.I. Joe and Cobra action figures to man the Cobra Terror Drome! Don't forget the Joes in the jail cell—help them escape and get 'em back to Headquarters on the double! Yo Joe! (Other figures sold separately.) (ILL. 17)

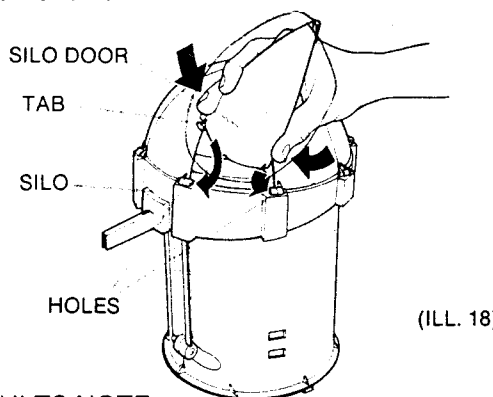

(ILL. 18)

18 ADULTS NOTE: If silo doors should detach from silo during play: Disassemble lower bay doors, jail and bulkheads. Lift off upper deck from lower bay. Gently squeeze bottoms of detached silo door and insert tabs into holes in silo. (ILL. 18)
To reassemble: Line up arrow on upper deck with arrow on lower bay and slide deck into position. Reassemble lower bay bulkheads, jail and bay doors.

TERROR DROME

- 1) REINFORCED "HEAVY-ARMOR" COBRA BATTLE RAMPART
- 2) VEHICLE DIAGNOSTIC ANALYSIS/SERVICE BAY
- 3) REFUELING/ENERGIZING STATION
- 4) RADOME/REINFORCED CANNON TOWER
- 5) PERIMETER DEFENSE SENSORS/SCANNERS
- 6) MUNITION STORAGE DEPOT
- 7) LAUNCH SILO ACTIVATION CHAMBER
- 8) PRISONER CONTAINMENT CHAMBER
- 9) ENERGY-FIELD CONTAINMENT DOOR
- 10) LAUNCH PREPARATION WORK STATION
- 11) THERMAL COMPUTER EMISSION VENT
- 12) LAUNCH SILO THERMAL THRUST VENTS
- 13) LAUNCH SILO BLAST SHIELDS
- 14) FIRE CONTROL/LAUNCH SILO COMMAND SEAT
- 15) FIRE CONTROL/GUIDANCE MONITORS
- 16) LAUNCH PREPARATION PERIMETER LEVEL
- 17) LASER CANNON COMMAND SEAT
- 18) TOWER MOUNTED "WHITE HEAT" LASER CANNONS
- 19) BLAST DOOR MOUNTED LASER CANNONS
- 20) SWING-OUT BLAST DOOR/STRUT DAMPENED

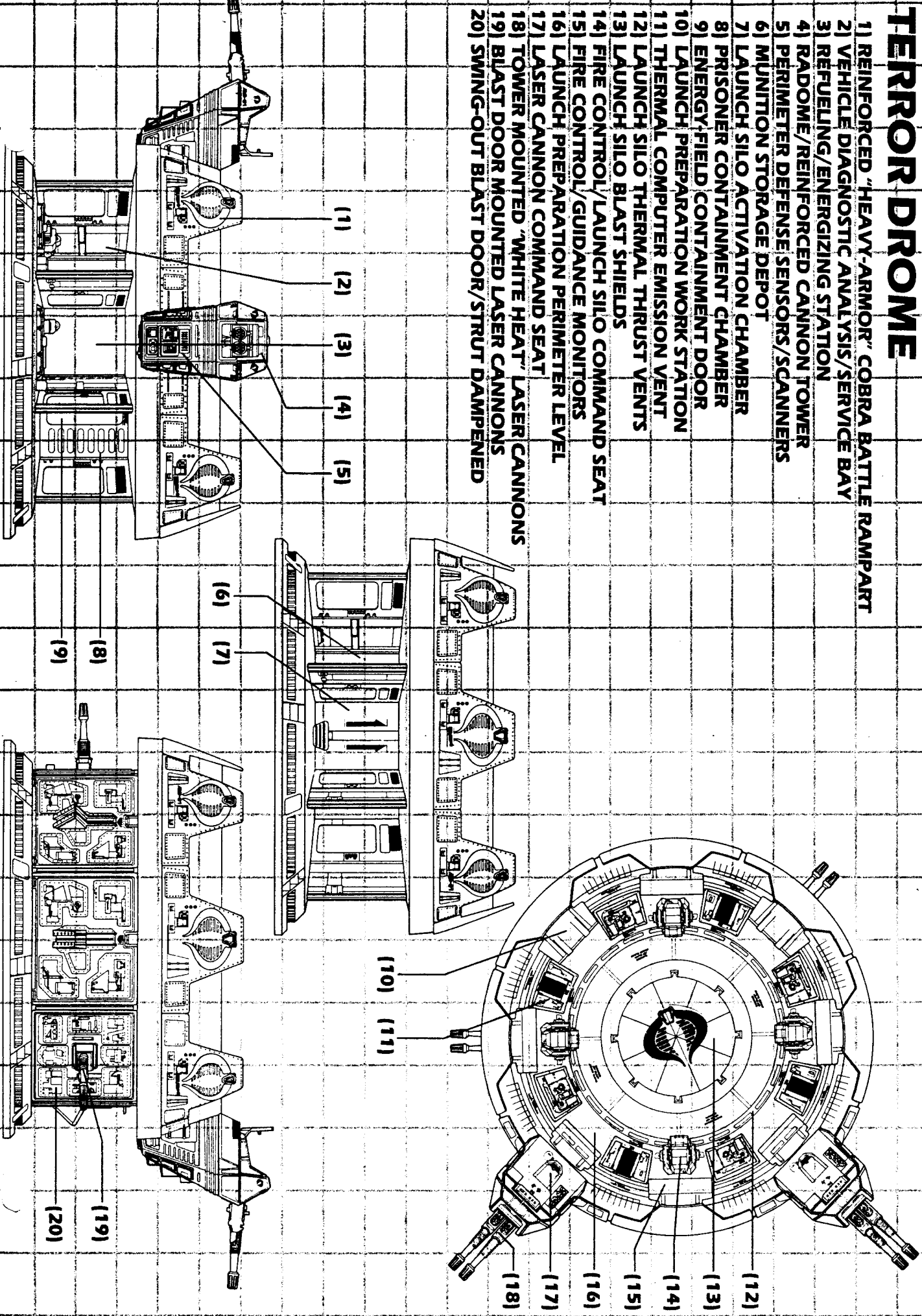

TERROR DROME FIREBAT INSTRUCTIONS

Remove all pieces from plastic frames. If you have difficulty, use safety scissors.

ENGINE HALVES

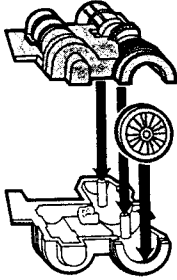

ILL. 1

INTAKE

SLOT

TAB

SLOT

FUSELAGE BOTTOM

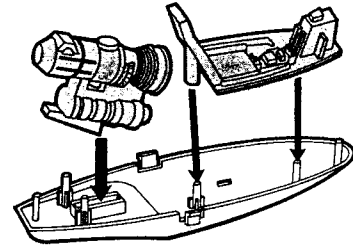

INTERIOR

ILL. 2

POSTS

- 1 Fit engine intake into curved slot in engine half. Snap engine halves together. (ILL. 1)

- 2 Fit holes in interior over posts in fuselage bottom. Fit tab on engine into slot in fuselage bottom and tilt engine forward. (ILL. 2)

HATCH

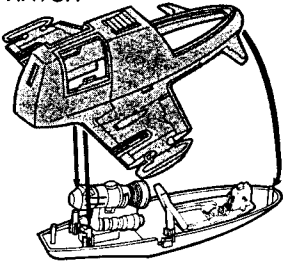

FUSELAGE TOP

HOLES

ILL. 3

POSTS

LEFT ENGINE COVER

LONG TAB

EXHAUST

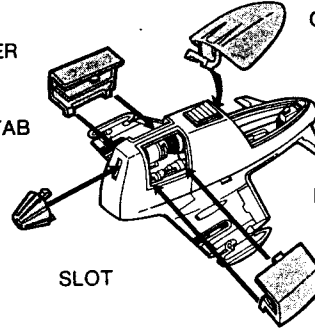

CANOPY BAR

TAB

ILL. 4

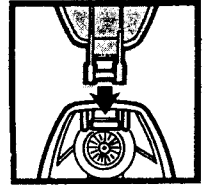

RIGHT ENGINE COVER

- 3 Line up holes in rear of fuselage top over posts on rear of fuselage bottom and snap together. NOTE: If hatch should detach from Firebat during play, fit front of hatch cover into hatch opening and snap into place. (ILL. 3)

- 4 With long tab on top, snap engine exhaust into slot in rear of fuselage. Snap left and right engine covers (marked "LEFT" & "RIGHT") over engine openings. Snap canopy bar over tab above seat. (ILL. 4)

LEFT STABILIZER

LEFT LANDING GEAR "L"

RIGHT LANDING GEAR "R"

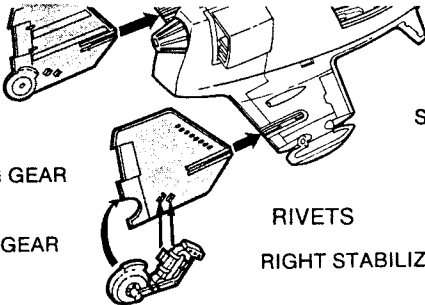

SLOT

ILL. 5

RIVETS

RIGHT STABILIZER

LEFT OUTER WING "L"

RIGHT WING

RIGHT OUTER WING "R"

ILL. 6

HOLES

TABS

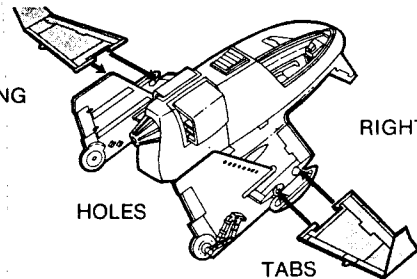

- 5 Snap tabs on right landing gear (marked "R") into holes in right stabilizer. Slide slot in right stabilizer (rivets face outward) over right wing as shown. Repeat with left stabilizer and landing gear (marked "L"). (ILL. 5)

- 6 Fit one tab on right outer wing (marked "R") into one hole in right wing. Snap second tab into place. Repeat with left outer wing (marked "L"). (Fold outer wings to land Firebat in Terror Drome silo.) (ILL. 6)

MISSILES

BOMBS

INNER WING

BELLY GUN

FUSELAGE BOTTOM

OUTER WING

ILL. 7

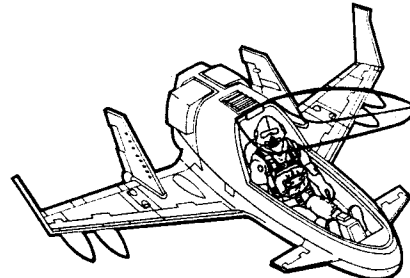
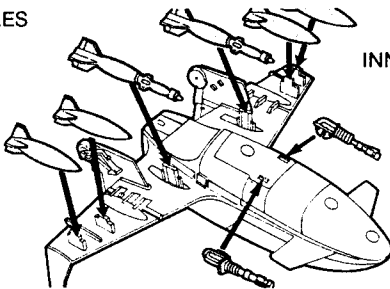

ILL. 8

- 7 Fit slots in 2 missiles over tabs underneath inner wings. Fit slots in 4 bombs over tabs underneath outer wings. Insert rear tab on belly gun into slot underneath fuselage and snap front tab into place. Repeat with second belly gun. (ILL. 7)

- 8 Open canopy and place Cobra pilot A.V.A.C. in Firebat cockpit. (Figure sold separately.) Fold wings and load into Terror Drome silo. (ILL. 8)

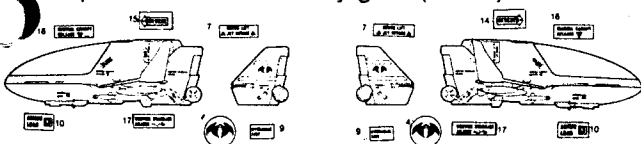

ILL. 9

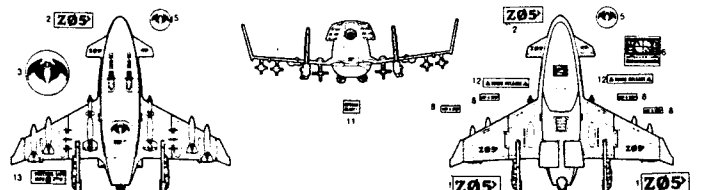

- 9 Peel and apply labels as shown. (ILL. 9)

TERROR DROME FIREBAT

- 1) FIRE CONTROL RADAR
- 2) INFRARED HUD (HEAD UP DISPLAY) IMAGING
- 3) AIR INDUCTION VENTS
- 4) EPOXY COMPOSITE ENGINE COVERS
- 5) INTERNAL FUEL TANKS
- 6) COBRAJET F404 AFTERBURNING TURBOJET
- 7) VERTICAL STABILIZER WINGLETS
- 8) AIR TO SURFACE CONDOR BOMBS
- 9) SUPER-REINFORCED TITANIUM FOLDING WING
- 10) HIGH-DRAG MK.38 SNAKEYE GUIDANCE BOMB
- 11) HORIZONTAL STABILIZING FRONT CANNONS
- 12) 25MM TWIN COAXIAL FIRING CANNONS
- 13) LAYERED COMPOSITE/TITANIUM BODY
- 14) VERTICAL LANDING STRUT/WHEEL ASSEMBLY

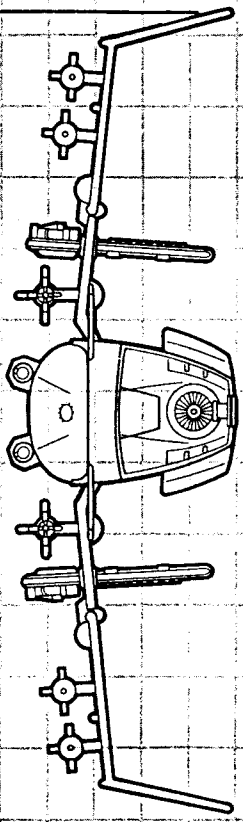
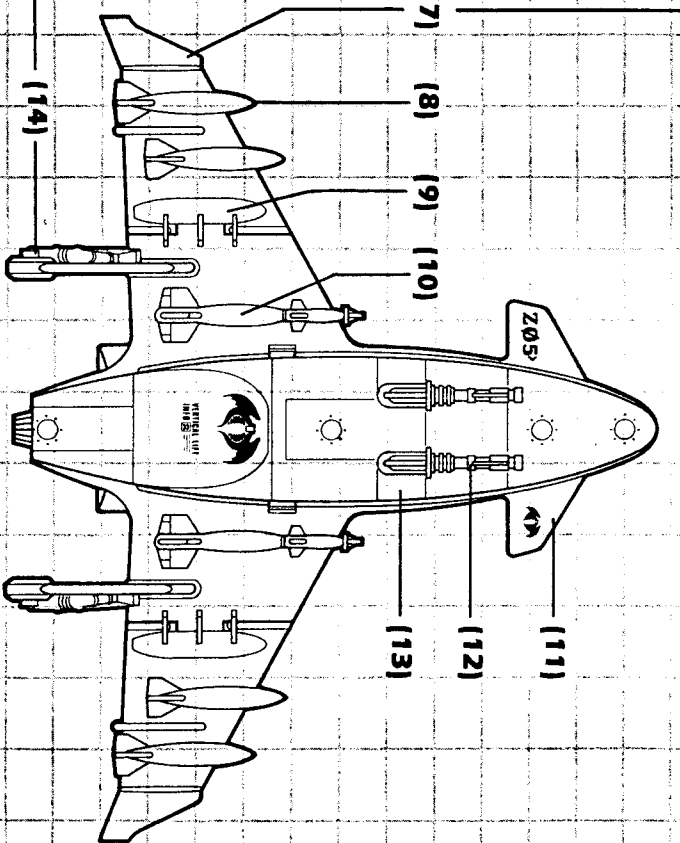
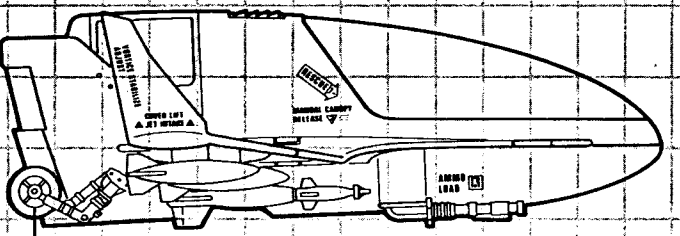
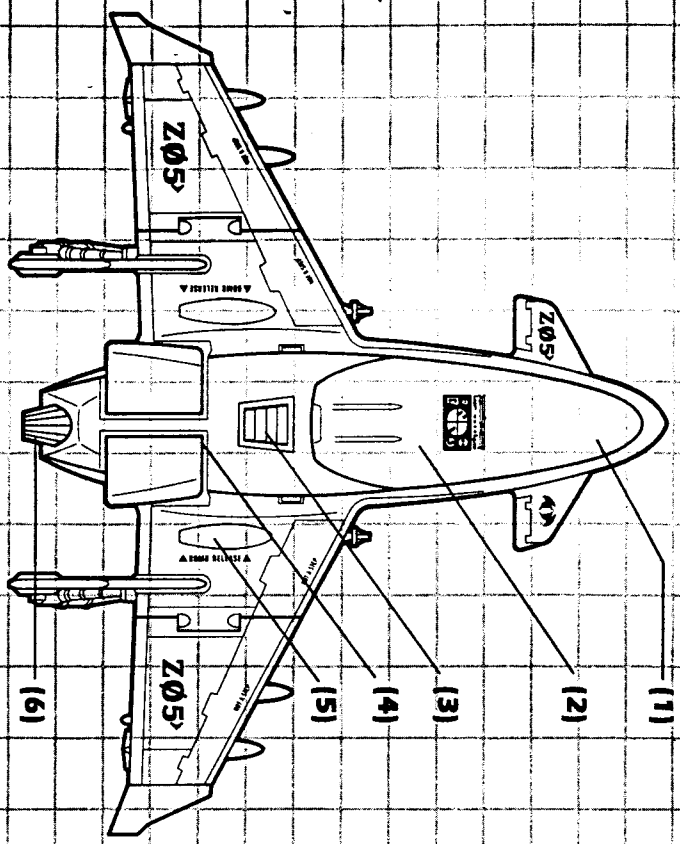

TERROR DROME LABEL PLACEMENT INSTRUCTIONS

Peel and apply the following labels as shown:

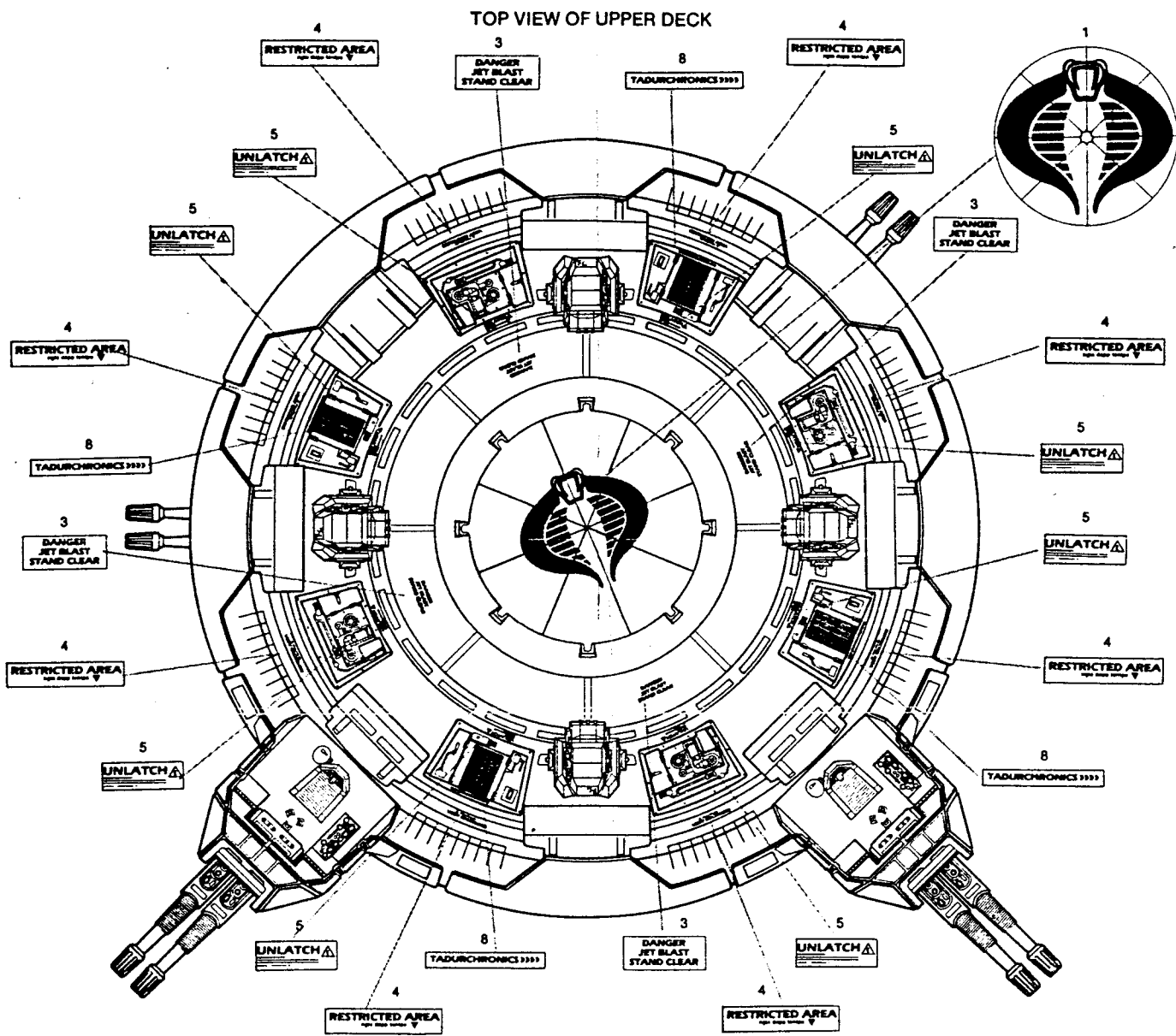

COMPUTER STATION

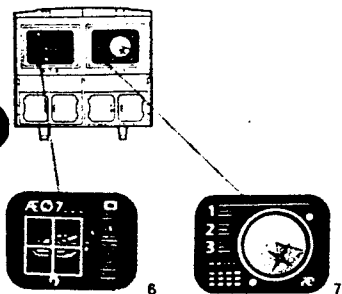

18 SERVICE PAD

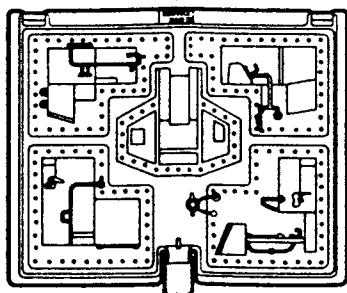

BAY DOOR

WORK STATION

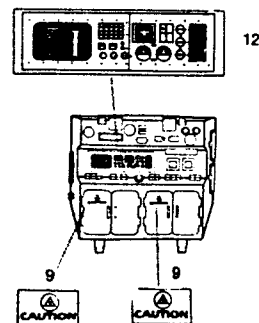

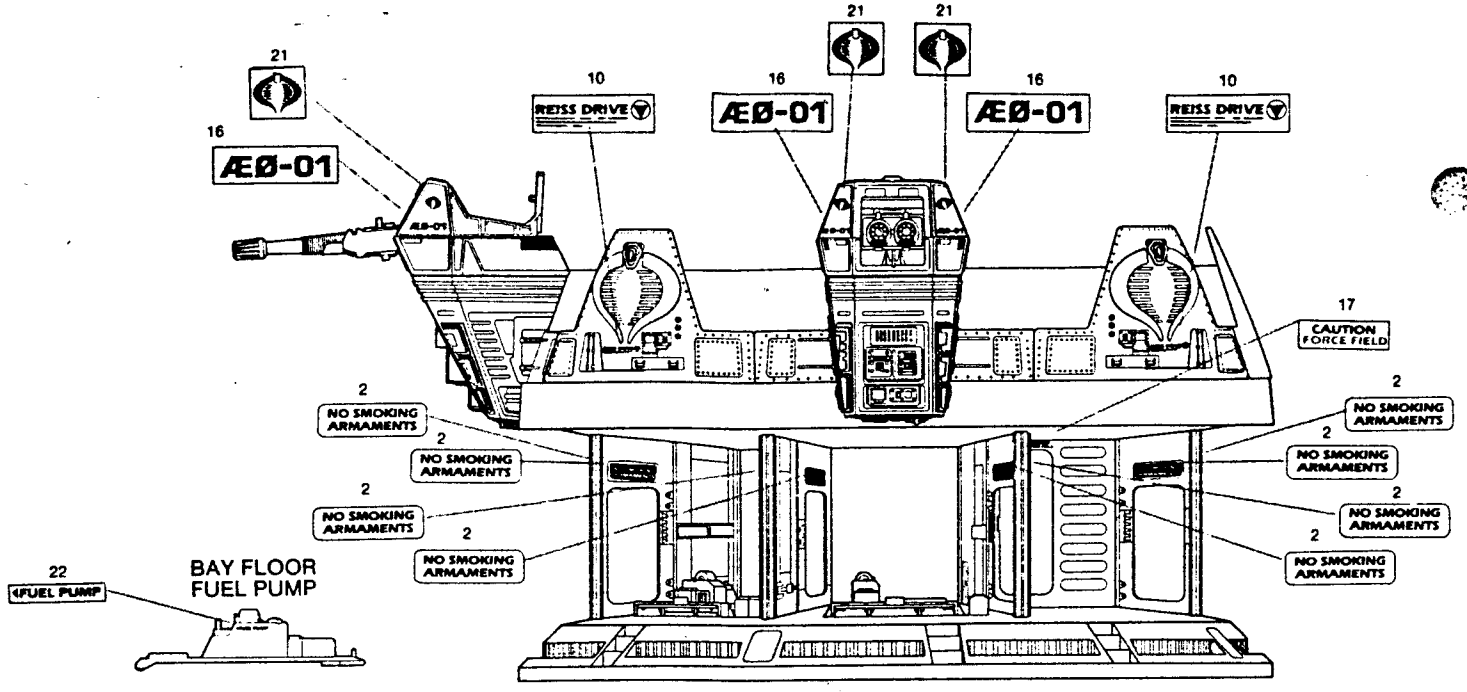

FUEL STATIONS AND JAIL CELL

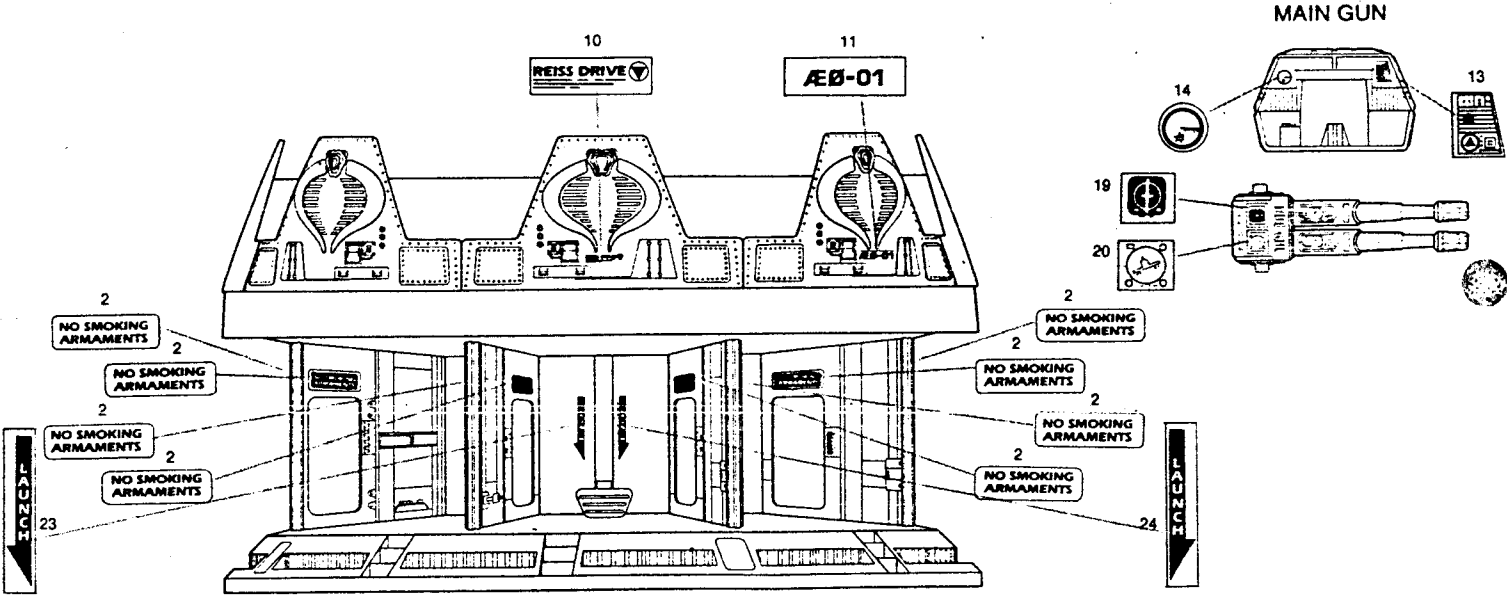

LAUNCH LEVER

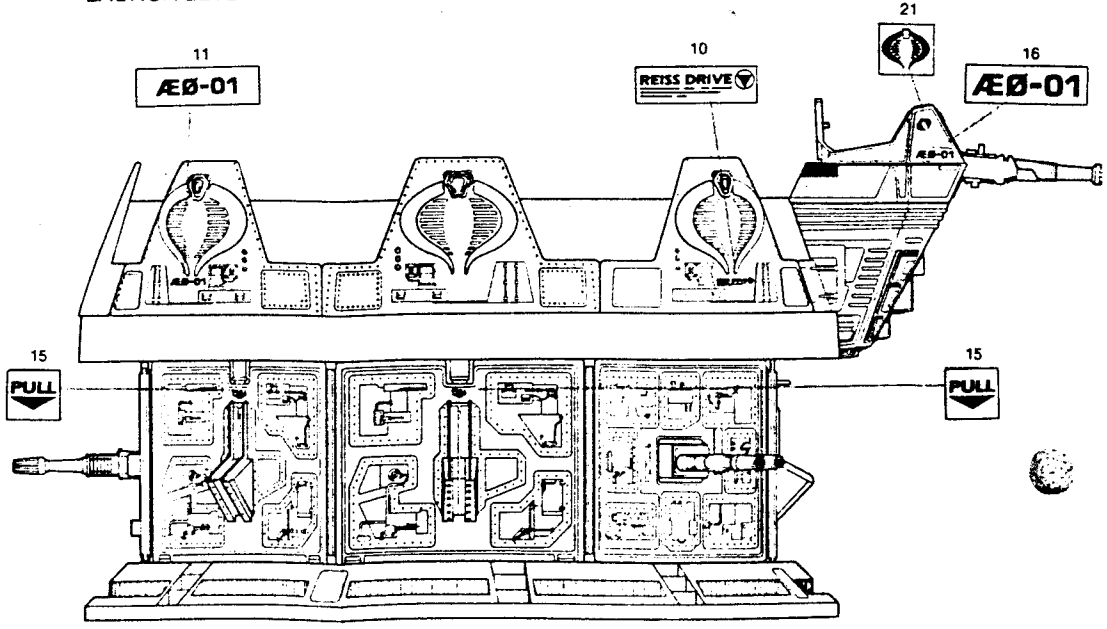

BATTLE STATION DOORS